

QRP-DWM Schematic

Directional Coupler / Power Meter v.1a

By: W5USJ 14 Jul 2018

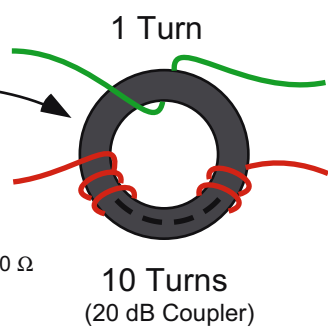
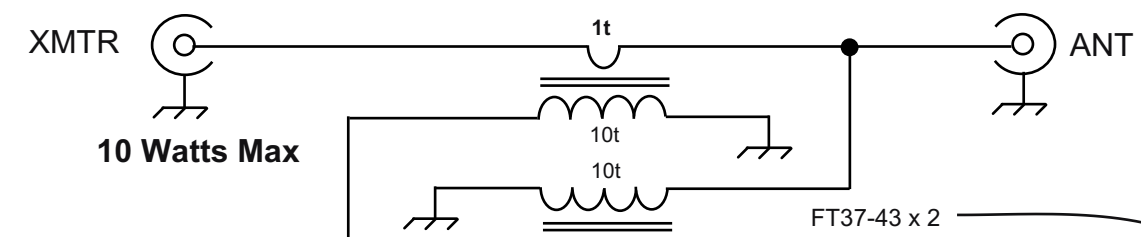

Adjustment Reference

Voltage	Power
$V_{adj} \times 1.0$	10 watts
$\times 0.3162$	1 w -10 dB
$\times 0.1$	0.1 w -20 dB

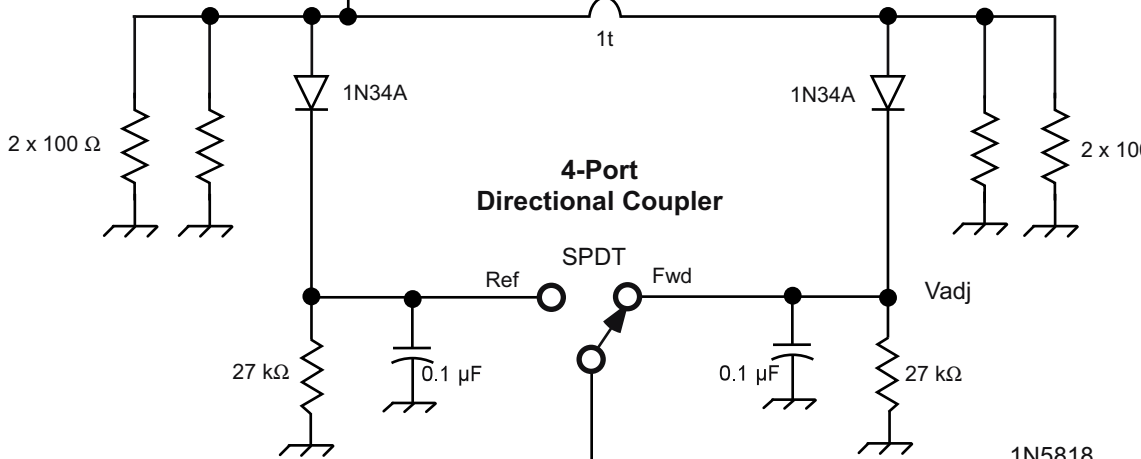

See Instruction Document for Setup and Test Procedures

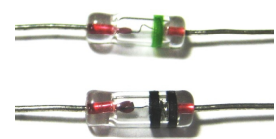
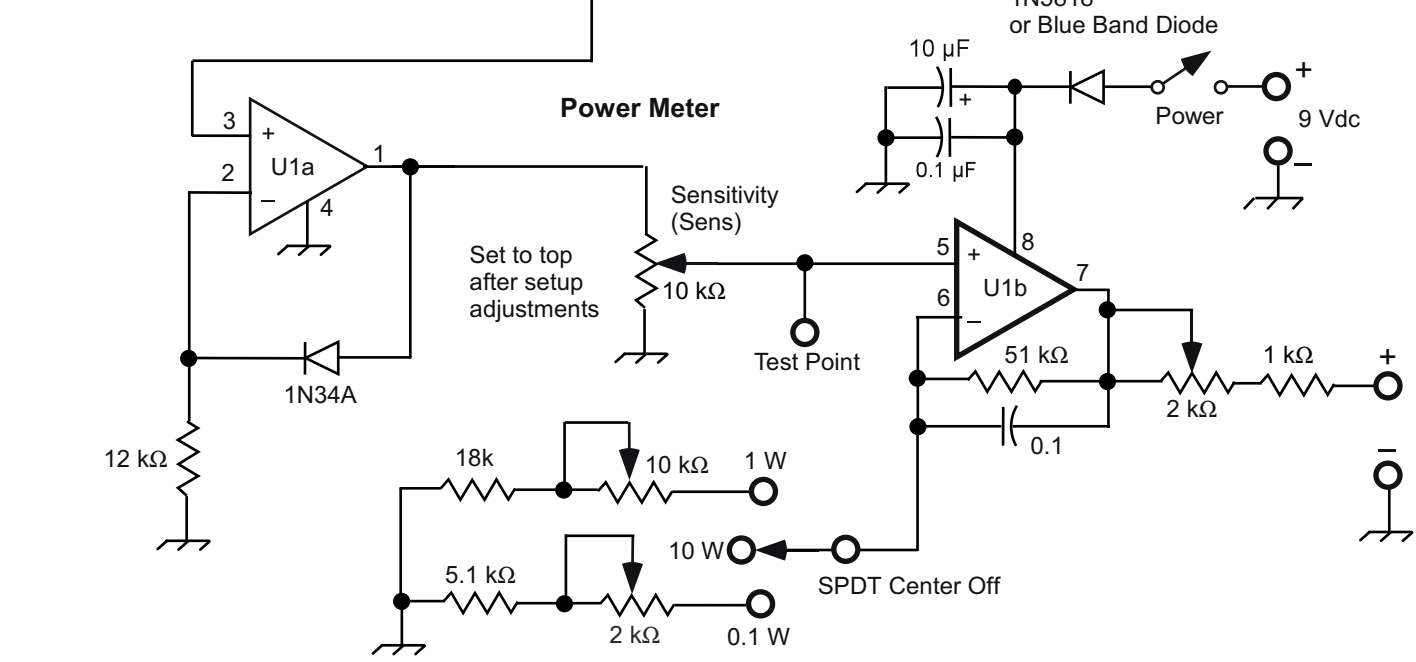

Use only 1N34A Point Contact diodes or equivalent, e.g. 1N60, 1N270



Source: Amazon